

# Application Note 53

## Interfacing a PC Parallel Port to the TMC22x5y RBUS serial interface

This circuit shows how to communicate through a IBM-compatible parallel printer port of a generic PC to the TMC22x5y RBUS serial interface, using the Fairchild 'Raydemo' revision 2A software.

To control the TMC22x5y digital video decoder with 'Raydemo' revision 2A software, simply install onto any windows based PC platform, and launch raydemo.exe. The block diagram shows the Fairchild multimedia evaluation board which will be available 3Q96. To communicate with the TMC22x5y double click onto the TMC22x5y decoder symbol and select the RBUS interface. The "Raydemo" revision 2A allows two serial addresses, SA[2:0] equal to 000 (upper decoder symbol) or 001 (lower decoder symbol).

The XLUT programming is implemented with a pick and drag. To operate place the cursor over the XLUT point you wish to program, click the mouse, and drag up or down to the desired level of cross fade between the comb filter output and the bandsplit output. Note that a level of '0' will invoke the 'special function' mode, and the configuration of the XLUT can be controlled by register 0Eh bits 7 and 6.

The register maps and XLUT tables provided are not recommended, however they do provide a good starting point.

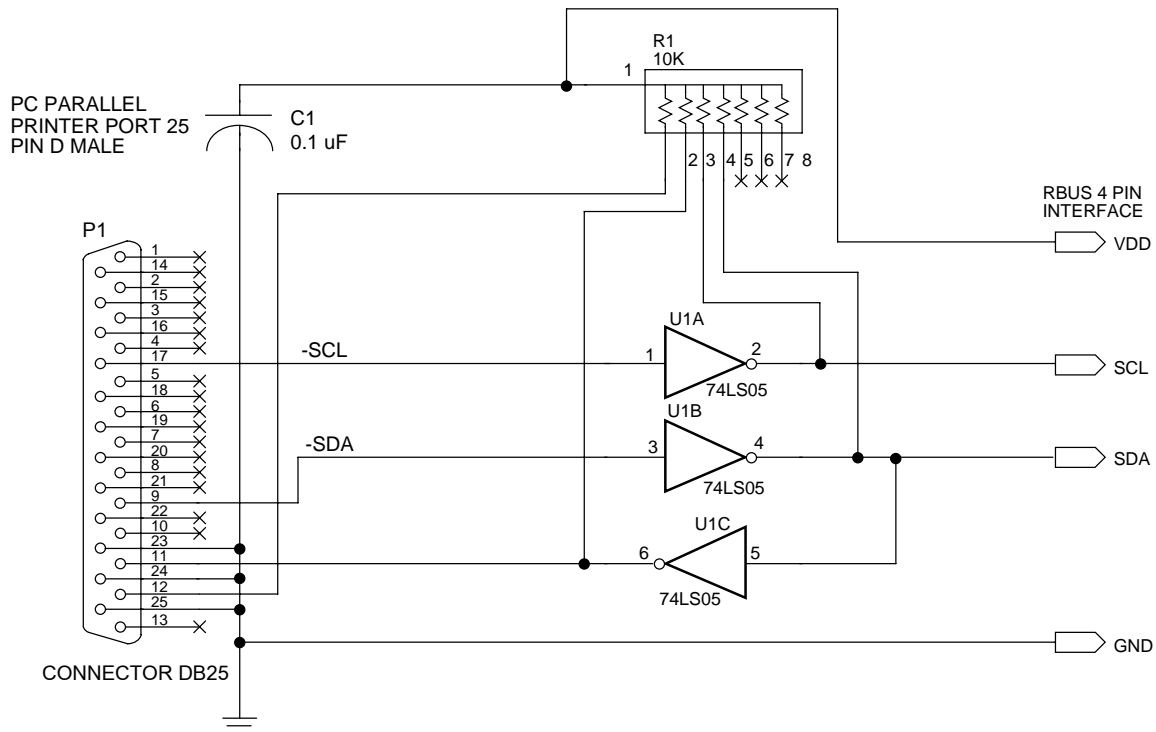

**LIFE SUPPORT POLICY**

FAIRCHILD'S PRODUCTS ARE NOT AUTHORIZED FOR USE AS CRITICAL COMPONENTS IN LIFE SUPPORT DEVICES OR SYSTEMS WITHOUT THE EXPRESS WRITTEN APPROVAL OF THE PRESIDENT OF FAIRCHILD SEMICONDUCTOR CORPORATION. As used herein:

1. Life support devices or systems are devices or systems which, (a) are intended for surgical implant into the body, or (b) support or sustain life, and (c) whose failure to perform when properly used in accordance with instructions for use provided in the labeling, can be reasonably expected to result in a significant injury of the user.
2. A critical component in any component of a life support device or system whose failure to perform can be reasonably expected to cause the failure of the life support device or system, or to affect its safety or effectiveness.